

6^{1/2}" - PAPER CONE DRIVER - 170 mm**CLASSIC SERIES**

Extended bass response (F_s : 50 Hz)
 Paper cone
 Foam suspension
 Long excursion
 High temperature voice coil
 Stamped steel chassis

Réponse étendue dans le grave (F_s : 50 Hz)
 Cône papier
 Suspension mousse
 Grande excursion
 Bobine haute température
 Châssis acier embouti

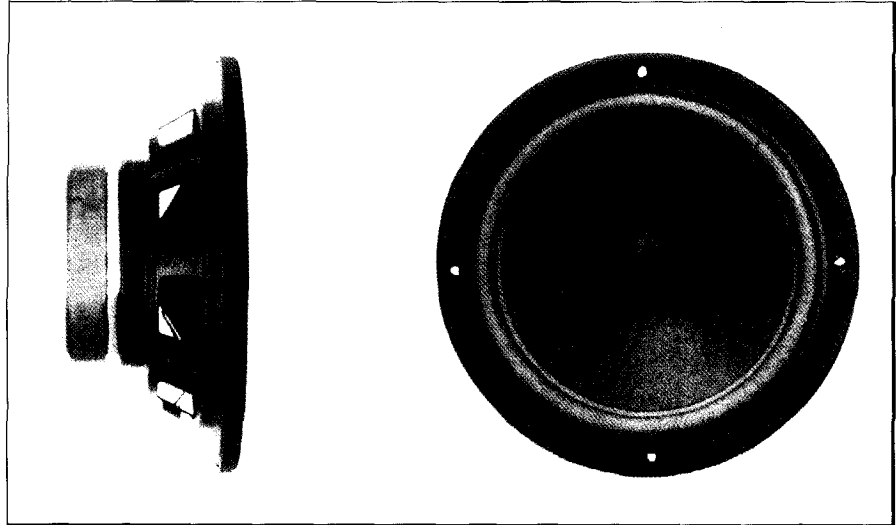

The paper cone foam surround 6^{1/2}" bass midrange offers a combination of extended frequency response, low resonance and high sensitivity. Ideally suited for 2-way bookshelf systems. The high temperature 1" voice coil ensures excellent power handling capacity. The "Suggested applications" charts indicate various driver loads, included the box alignment used to measure the response curve (V_b REF). The response curves shown on the diagram indicate the predicted low end response of the driver in the suggested box volume (V_b) with suggested port (D_p - L_p).

Equipé d'un cône en papier et d'une suspension mousse, ce haut-parleur de 170 mm est idéal pour une enceinte 2 voies de qualité et de bon rendement. Sa bobine haute température sur support aluminium lui confère une bonne tenue en puissance. Le tableau "Suggested applications" indique différents types de charge dont celui utilisé pour la mesure de la courbe de réponse (V_b REF). Les courbes publiées correspondent à la réponse dans le grave pour un volume (V_b) et une dimension d'évent donnée (V_p - L_p).

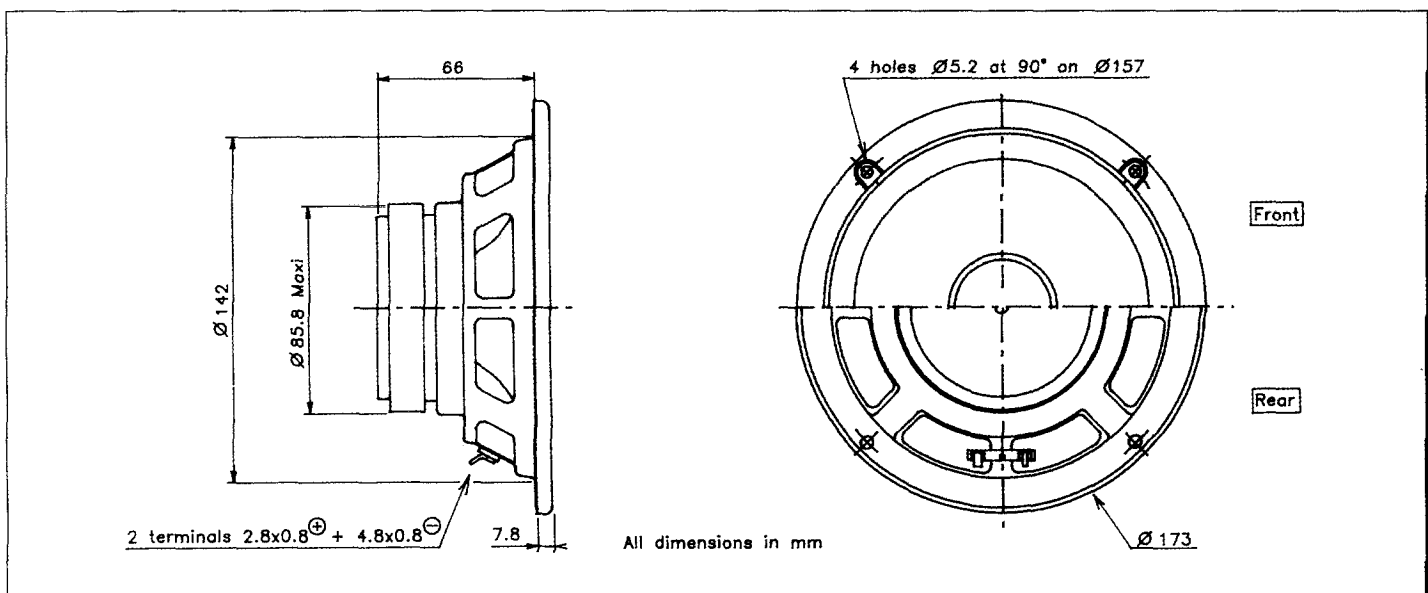

RESPONSE CURVE
refer to page 16

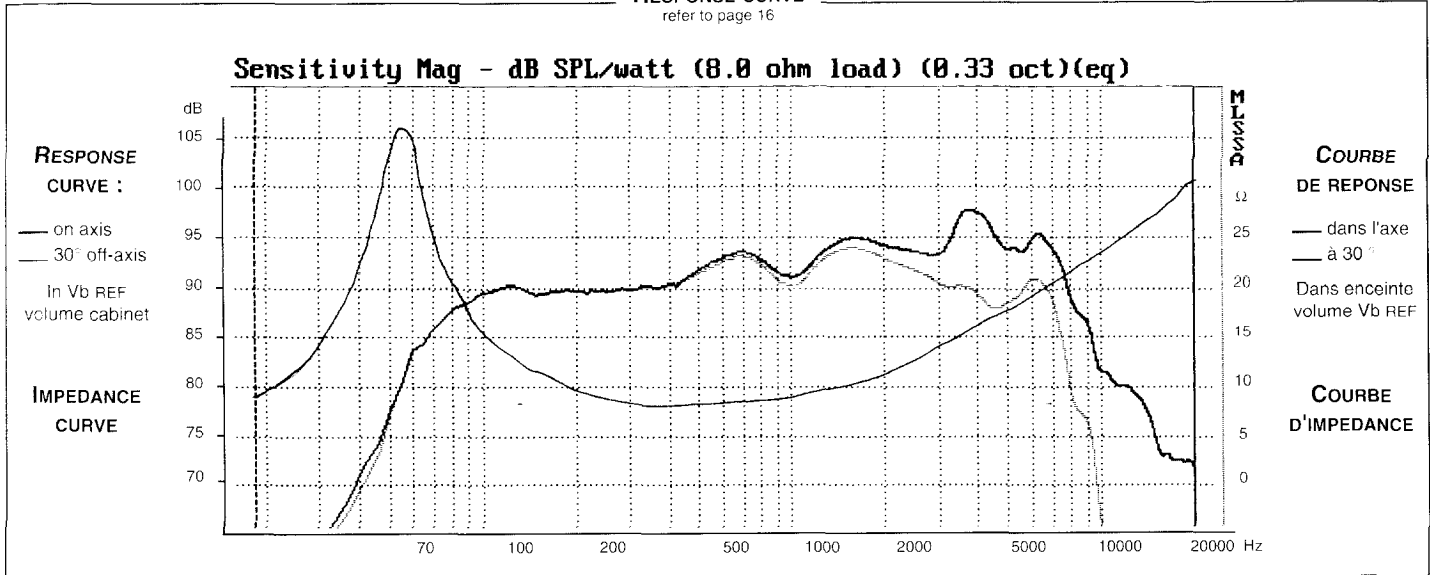

SPECIFICATIONS			
Technical Characteristics	Symbol	Value	Units
PRIMARY APPLICATION			
Nominal Impedance	Z	8	Ω
Resonance Frequency	Fs	50	Hz
Nominal Power Handling	P	50	W
Sensitivity	E	90	dB
VOICE COIL			
Voice coil diameter	Ø	25	mm
Minimum Impedance	Zmin	7,7	Ω
DC Resistance	Re	6,8	Ω
Voice Coil Inductance	Lbm	0,08	mH
Voice coil Length	h	11	mm
Former	-	Aluminium	-
Number of layers	n	2	-
MAGNET			
Magnet dimensions	Ø x h	84 x 15	mm
Magnet weight	m	0.35	kg
Flux density	B	1,1	T
Force factor	BL	5,8	NA ⁻¹
Height of magnetic gap	He	5	mm
Stray flux	Fmag	-	Am ⁻¹
Linear excursion	Xmax	±3	mm
PARAMETERS			
Suspension Compliance	Cms	1,24.10 ⁻³	mN ⁻¹
Mechanical Q Factor	Qms	2,46	-
Electrical Q Factor	Qes	0,52	-
Total Q Factor	Qts	0,43	-
Mechanical Resistance	Rms	1,06	kg s ⁻¹
Moving Mass	Mms	8,3.10 ⁻³	kg
Effective Piston Area	S	1,4.10 ⁻²	m ²
Volume Equivalent of Air at Cas	Vas	34,7.10 ⁻³	m ³
Mass of speaker	M	0.95	kg

APPLICATION PARAMETERS		
Vb	Box volume	dm ³
Fb	Tuning frequency	Hz
Dp	Port diameter	cm
Lp	Port length	cm

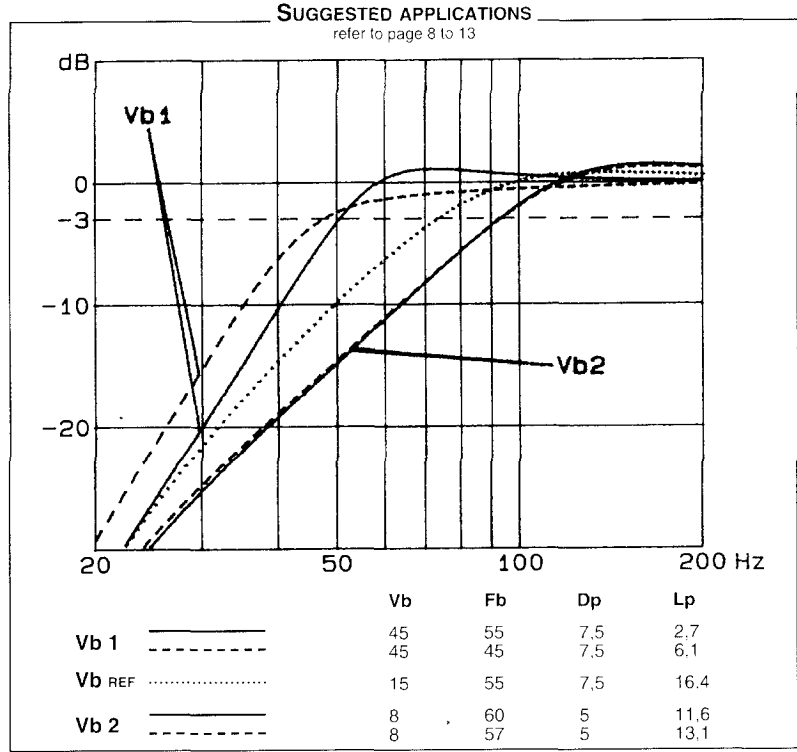
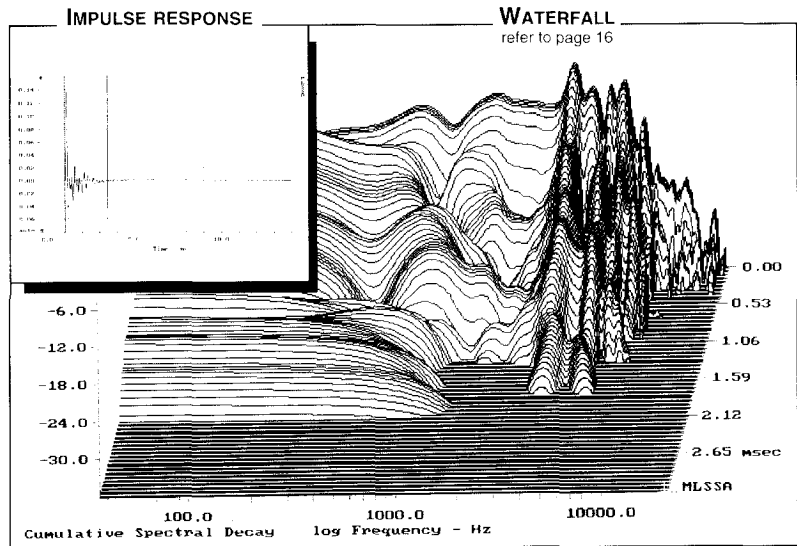

Please refer to method of measurement and measurement conditions pages 15 to 19.
Audax may, without prior notification modify the specifications on its products further to research and development requirements